



THE AIRPLANE FACTORY (Pty) Ltd, Registration no 2002/022837/07
Hangar 8 Tedderfield Airpark, Nettleton Road, Eikenhof, 1872, Johannesburg South
PO Box 308, Eikenhof, 1872, South Africa. Tel: +27(0)11 948 9898 Fax: +27(0)86 632 4493
E-mail: sales@airplanefactory.co.za Web: www.airplanefactory.co.za

SAFETY ALERT

#0005

Page 1 of 2

The Airplane Factory (Pty) Ltd considers compliance with all Safety Alerts mandatory

RELEASE DATE: 14 March 2014

EFFECTIVE DATE: 14 March 2014

SUBJECT: Fuel pickup in the fuel tank. The new style fuel pickup inside the fuel tanks could inadvertently be turned while installing fuel line fittings during assembly or maintenance. The pickup could be turned so that the pickup is facing upwards which means that up to 12 litres (3 US gallons) unusable fuel is left in the tank.

MODELS AFFECTED: All Sling models manufactured after the 1st June 2013.

COMPLIANCE TIME: At the next 100 hour MPI and service.

PURPOSE: A small P clamp riveted to the fuel tank rib to be fitted in order to prevent the fuel pickup from turning upwards in the fuel tank.

PARTS/EQUIPM LIST: 2 x Small aluminium P clamps made from 0.64 mm 6061 T6 aluminium
2 x 3.2 x 10 mm sealed pop rivets (the back end of the rivet is sealed)
2 x Cork Gaskets
2 grams Fuel tank sealant - Flamemaster CS3204 B1/2 (with hardener)
Allen keys to remove the covers and tank end cover plate.
Torch
Air angle drill (not electric – risk of fire)
3.3 mm drill bit

INSTRUCTIONS: Remove the inspection hatches under the leading edges of both wings to access the fuel tank end ribs.
First check that the pickup is of the new design: The original design (which does NOT need modification) used brass fuel line fittings and the pickup and return were next to each other on the round tank cover plate.
The new design has blue aluminium fittings and the pickup and return are in the position as shown in the attached drawing.
If the tank pickup is of the new design, look first for the single rivet in the corner as shown in the “DRILLING DETAIL” in the attached drawing. If the rivet is there it means the modification has already been done.
If the pickup is of the new design and there is no rivet in the corner of the rib then the P clamp restraint strap must be fitted – follow the instructions below.
Keep a fire extinguisher close by at all times.
Remove the positive terminal from the main battery.
Drain the fuel out of the tank by removing the drain valve.

Remove the round tank rib cover plate and cork gasket. Take note of its position for accurate re-assembly later.

See the attached instructions for further details.

Be sure to use an air drill because an electric drill could cause a fire.

ITEM NO.	PART NUMBER	DESCRIPTION	QTY.
1	FUEL TANK RIB STEP 3	WING FUEL TANK RIB 1	1
2	FUEL PICKUP FITTING		
3	FUEL PICKUP RESTRAINT STRAP		

Step 1
If the part has not been supplied with this Service Bulletin, fabricate the part shown. (see page referring to its fabrication)

Step 2
Slide the restraint strap over the fuel pickup mesh filter up to its base at the end of the copper pipe.

Step 3
Loosen the nut slightly at the elbow to allow the pipe to rotate into position as needed, then, with a suitable marking pen, hold the restraint strap in place on the rib and mark where a 3.3mm dia hole is to be drilled. Re - tighten the nut at the elbow.

Step 4
slide the restraint strap away slightly and drill a 3.3mm hole into the rib (see drilling detail for hole position). Before riveting in place, apply Flamemaster CS3204 B1/2 under the restraint strap, in the rivet hole and under the rivet head. Rivet the Restraint strap in place.

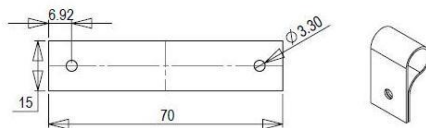

**FUEL PICKUP RESTRAINT STRAP
(SEE PAGE REFERING TO FABRICATION)**

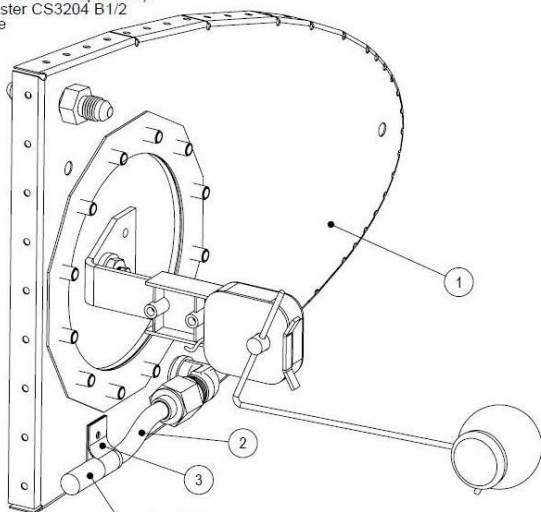

ASSEMBLED VIEW

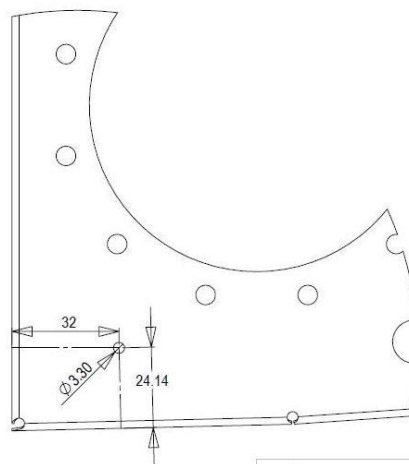

DRILLING DETAIL

DESCRIPTION		pg 1
FUEL PICKUP RESTRAINT STRAP		pg 1/2
Slng	Date:2014/03/14	Revision

After assembling the fuel tank and allowing 24 hours for the sealant to dry, check for leaks by pressurizing the tank - place a hose onto the tank overflow pipe and blow using a hard breath of air – do not use air pressure from a compressor because the tank may burst from over pressurization. Brush soapy water over the gasket area, bolts, fittings and rivet to check for leaks.

Fill 1 litre of fuel into each tank and then pump the fuel out. Unused fuel left in each tank should be less than 0.5 litres.

Fill the tanks completely and again check for fuel leaks or sweating.

Close the inspection hatches under the wing.

Attach the positive terminal on the battery.

Run the engine at 4,000 RPM for 5 minutes on each wing tank before flying.